

(this space left for blank for recording)

Prepared by:
ALBERTELLI LAW
1 INFORMATION WAY
SUITE 201
LITTLE ROCK, AR 72202
(501) 406-0855
ALAW File 24-029828

**MORTGAGEE'S NOTICE OF DEFAULT AND INTENTION TO SELL
YOU MAY LOSE YOUR PROPERTY IF YOU DO NOT TAKE IMMEDIATE ACTION
IF THIS PROPERTY IS SOLD YOU WILL REMAIN LIABLE FOR ANY DEFICIENCY
WHICH THEN EXISTS AND AN ACTION TO COLLECT IT MAY BE BROUGHT AGAINST
YOU
THIS IS AN ATTEMPT TO COLLECT A DEBT AND ANY INFORMATION OBTAINED WILL
BE USED FOR SUCH PURPOSE**

NOTICE IS HEREBY GIVEN that on December 19, 2024 at or about 10:00AM, the subject real property described herein below will be sold at the Main Entrance of the Phillips County Courthouse, 620 Cherry Street, Helena, AR 72342 to the highest bidder for cash. The sale will extinguish all interests, including those of existing lien holders or previous owners in the property. THE TERMS OF SALE ARE CASH THE TIME OF SALE AND ALL TRANSFER TAXES WILL BE THE RESPONSIBILITY OF THE PURCHASER.

WHEREAS, the property secured under the Mortgage is located in Phillips County, Arkansas more particularly described as follows:

LOT NUMBERED FOUR HUNDRED NINETEEN, 1963 REDIVISION IN SYLVAN RIDGE SUBDIVISION, CITY OF WEST HELENA, ARKANSAS, AS PER PLAT AND DEDICATION THEREOF RECORDED IN PLAT BOOK 1, PAGE 32-A, AND DEED RECORD BOOK 425, PAGE 52, OFFICIAL RECORDS OF PHILLIPS COUNTY, ARKANSAS.

Street Address: 732 Forrest Hill Drive, West Helena, AR 72390

WHEREAS on December 18, 2002 Amy Smith a married person, and Monroe Smith, Jr. her husband, executed a Deed of Trust in favor of Wilson and Associates PA, as trustee for Countrywide Home Loans, Inc. Said Deed of Trust was recorded on January 3, 2003 in Book 800, Page 159 in the real property records of Phillips County, Arkansas. Said Deed of Trust was subsequently assigned to The Leader Mortgage Company by virtue of an assignment dated December 18, 2002 and recorded on July 29, 2004 in Book 825, Page 246 in the real property records of Phillips County, Arkansas. The assignment to The Leader Mortgage Company was re-recorded on September 21, 2004 in Book 827, Page 742 in the real

property records of Phillips County, Arkansas. Said Deed of Trust was subsequently assigned to U.S. Bank National Association by virtue of an assignment dated June 5, 2023 and recorded on June 14, 2023 in Book 2023, Page 4289 in the real property records of Phillips County, Arkansas. The party initiating foreclosure can be contacted at or in care of its servicer initiating foreclosure at: U.S. Bank National Association 2800 Tamarack Road Owensboro KY 42301 at Telephone No. 800-365-7772; and

WHEREAS, there may be tenants that claim an interest in the real property herein based upon said tenancy; and

WHEREAS, the undersigned is the attorney for the mortgagee and is acting on and with the consent and authority of the mortgagee who is exercising its power of sale under Ark. Code Ann. §18-50-115 which implies a power of sale in every mortgage of real property situated in this state that is duly acknowledged and recorded; and default has occurred in the payment of said indebtedness, specifically the installment due July 1, 2020, and each subsequent payment to date are now due; and the holder of the debt has requested the undersigned to sell the property to satisfy said indebtedness. This sale is subject to all matters shown on any applicable recorded plat or bill(s) of assurance; any restrictive covenants, easements, set back liens or encroachments; any unpaid and/or delinquent taxes or special assessments; any statutory redemption rights of any governmental entity; any prior liens or encumbrances as well as any priority created by a UCC or fixture filing; and, to any matter that an accurate survey of the property might disclose. This property is being sold "as is" with no representation as the condition of any structure(s) thereon or the accuracy of the above legal description. Transfer taxes and recording fees are the responsibility of the purchaser.

WITNESS my hand this 22 day of October, 2024. U.S. Bank, National Association, by its attorney-in-fact, Albertelli Law

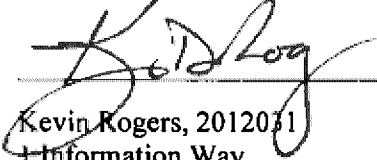
Kevin Rogers, 2012031
† Information Way
Suite 201
Little Rock, AR 72202
501-406-0855
A LAW No. 24-029828

ACKNOWLEDGEMENT

STATE OF ARKANSAS §
COUNTY OF PULASKI §

On this 22 day of October, 2024, before me, the undersigned officer, Kevin Rogers, personally appeared, known to me to be the person who subscribed to the within instrument and acknowledged that he executed the same for the purposes therein contained.

IN WITNESS WHEREOF, I hereunto set my hand and official seal.

My Commission Expires: 4/14/2033

Notary Public
I certify that this instrument was filed on 10/22/2024 12:18 PM and recorded in MORTGAGE Book 2024 TAMEKIA FRANKLIN Circuit Clerk - PHILLIPS County, AR
* MARGEN LEANN MONTGOMERY
COMM. EXP. 4-14-2033
No. 12722747
PULASKI COUNTY
NOTARY PUBLIC - ARKANSAS
by 